



2022

**76M - 77M LISCIA  
78M - 79 M C/COL.  
MATRICI DI TRANCIATURA DIN 9845**

Materiale: acciaio UNI X205Cr12 n°1.208  
Trattamento: tempra e rinvenimento  
Durezza: HRc 60-62  
Esecuzione: rettifica

Steel: uni x250Cr12 n° 1.208  
Hardness 60+/-2

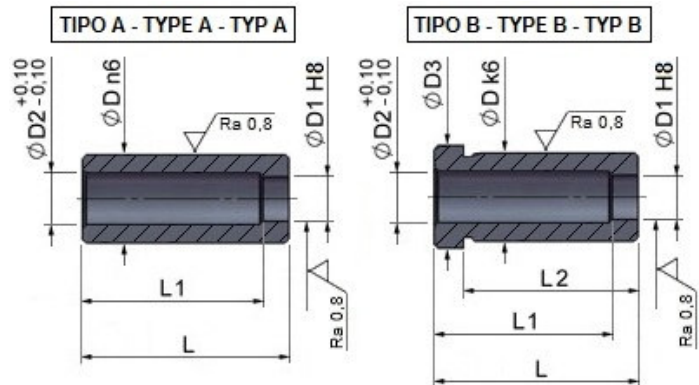

D1H8	D	LISCIA		CON COLLARE			
		76M L =20	77M L =28	D3	L-L2	78M L =20	79M L= 28
0.8-1.0	5	SOLO HSS		7	4	SOLO HSS	
1.1- 1.9	6	SOLO HSS	SOLO HSS	8		SOLO HSS	SOLO HSS
2-3.3	7	*	*	9		*	*
3.4-4	8	*	*			*	*
4.1 .. 5	10	*	*	12		*	*
5.1 .. 6	12	*	*	14		*	*
6.1 .. 8	15	*	*	17		*	*
8.1 .. 10	18	*	*	20		*	*
10.1 .. 12	22	*	*	24		*	*
12.1 .. 15	26	*	*	28		*	*
15.5-18	30		*	32			*
18.5-22	35		*	37			*
22.5-26	42		*	44			*
26.5-30	48		*	50			*